

TECHNICAL UPDATE

Date: April 12, 2006

To: StackTeck Customers

Subject: Mold Leveling Surfaces

In order to help align multi-level molds, mold leveling surfaces are located along the top corners of multi-level mold plates; each approximately 3"x 0.05" (*Fig. 1*).

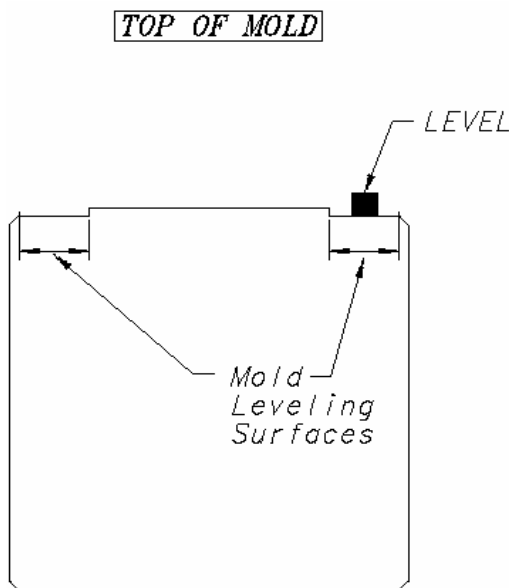

Fig.1 - PLAN VIEW

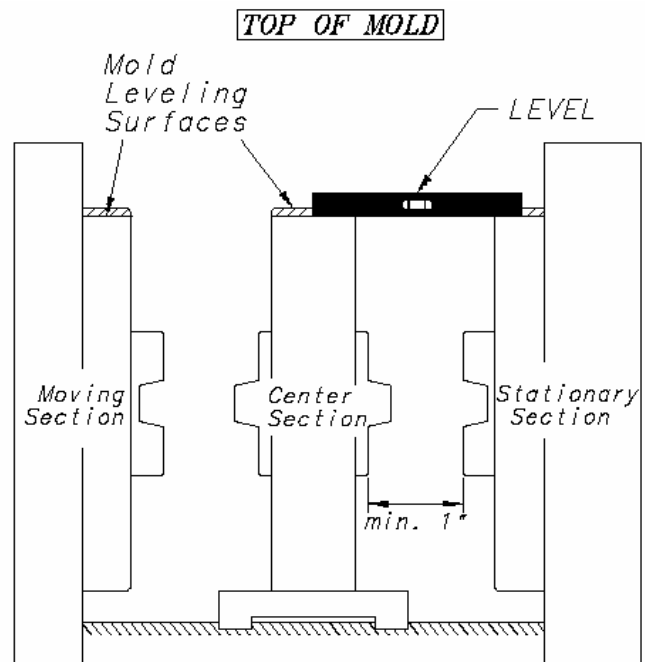

Fig.2 - SIDE VIEW (OPERATOR SIDE)

Instructions:

1. Locate the mold-leveling surfaces.
2. Open molds a minimum of 1-inch at the parting line. (*Fig.2*)
3. Place one end of a level on the center section, and the other end on the stationary/ moving section. (*Fig. 2*)
4. Proceed with mold support adjustments.

Should you have any inquiries, please contact our Technical Sales Managers.

Yours truly,

StackTeck